

THERMOCOUPLE

3 & 5 Pair Weldable

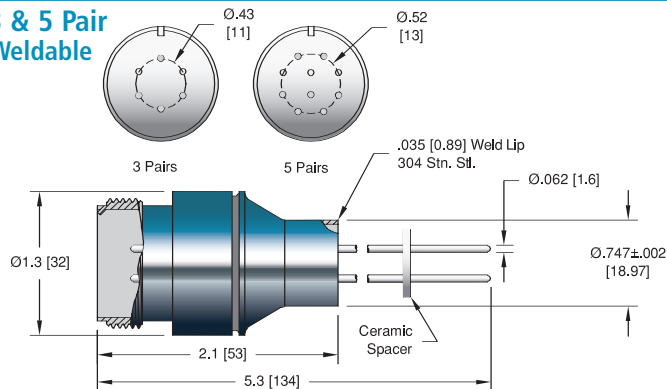

ISO KF

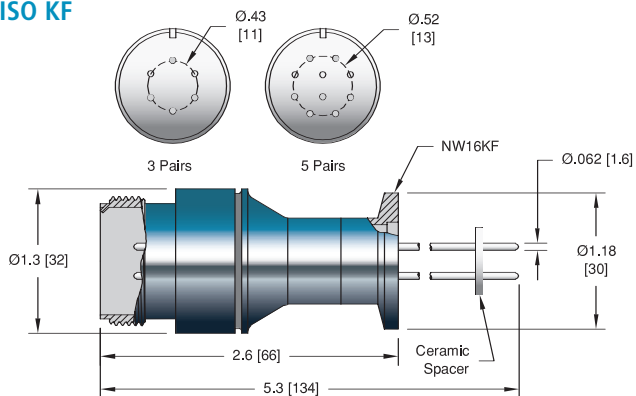

ConFlat - NW16CF

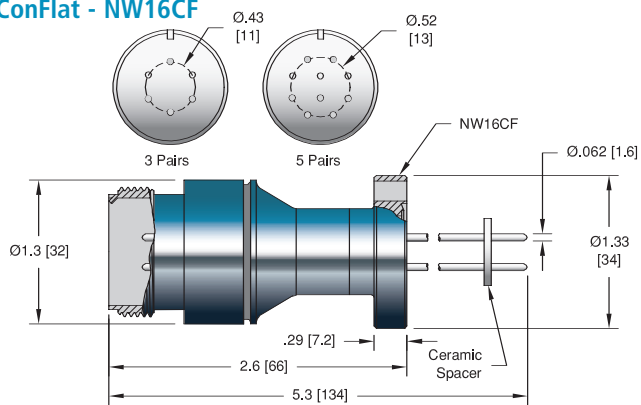

ConFlat - NW35CF

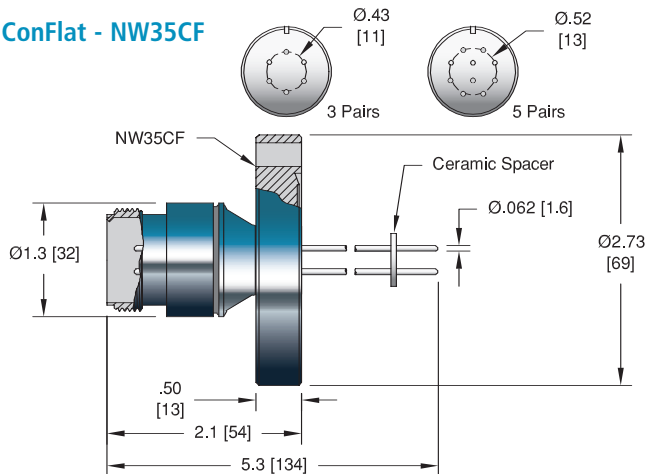

10 Pair Weldable

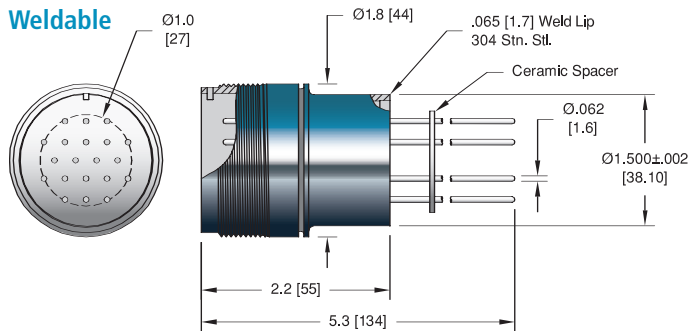

ISO KF

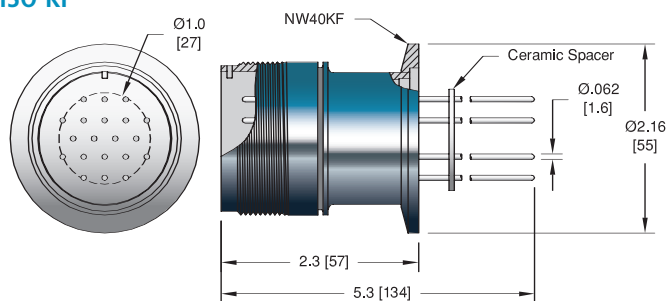

ConFlat

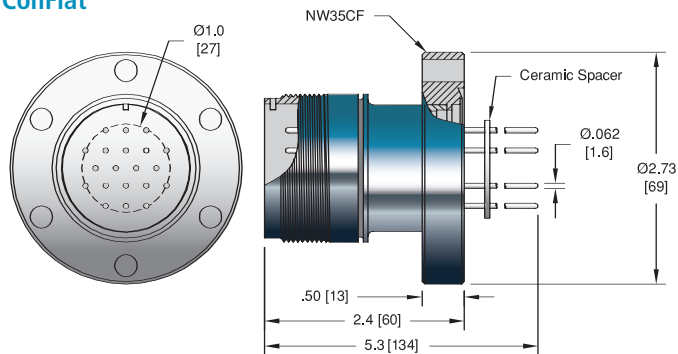

Specifications

Materials

- Shell: 304 Stainless steel
- Thermocouple materials: Chromel/Alumel (Type K)
- Insulation: Alumina ceramic
- Magnetic Materials: Yes

Temperature Range -269°C to 450°C

Pressure @ 20°C ISO KF 0 PSIG

- 3 Pair: 400 PSIG (28 Bar)
- 5 Pair: 350 PSIG (24 Bar)
- 10 Pair: 125 PSIG (8.6 Bar)



ANSI TYPE	THERMOCOUPLE MATERIALS	INSTALLATION	T/C PAIRS	PART NUMBER
K	Chromel/Alumel	Weld	3	10084-05-W
K	Chromel/Alumel	Weld	5	11342-08-W
K	Chromel/Alumel	Weld	10	11343-07-W



ISO FLANGE				
ANSI TYPE	THERMOCOUPLE MATERIALS	INSTALLATION	T/C PAIRS	PART NUMBER
K	Chromel/Alumel	NW16KF	3	18008-02-KF
K	Chromel/Alumel	NW16KF	5	17155-02-KF
K	Chromel/Alumel	NW40KF	10	18010-02-KF



CONFLAT FLANGE				
ANSI TYPE	THERMOCOUPLE MATERIALS	INSTALLATION	T/C PAIRS	PART NUMBER
K	Chromel/Alumel	1 1/3" NW16CF	3	10084-06-CF
K	Chromel/Alumel	2 3/4" NW35CF	3	10084-07-CF
K	Chromel/Alumel	1 1/3" NW16CF	5	11342-09-CF
K	Chromel/Alumel	2 3/4" NW35CF	5	11342-10-CF
K	Chromel/Alumel	2 3/4" NW35CF	10	11343-05-CF



ANSI TYPE	THERMOCOUPLE MATERIALS	DIMENSIONS H	L	T/C PAIRS	PART NUMBER
K	Chromel/Alumel	1.4 [36]	4.4 [112]	3	15911-02-A
K	Chromel/Alumel	1.4 [36]	4.4 [112]	5	15912-02-A
K	Chromel/Alumel	1.9 [49]	4.3 [109]	10	15913-02-A

Note that thermocouple contacts are included with all plugs.



TYPE	MATERIAL	TEMPERATURE MIN	TEMPERATURE MAX	GROOVE	PART NUMBER
Crimp	Chromel	-269	350	Yes	11259-05-X
Crimp	Alumel	-269	350	No	11259-06-X
Crimp Tool					2840-05

*Contacts priced and sold in packages of 5. See the Accessories section for more information on all accessories.

THERMOCOUPLE

